

# CM Lodestar electric chain hoists

- Designed and built to take the rigors of the touring industry
- Black powder coat finish for durability
- 115 VAC control circuit
- Heat treated formed steel chain guides
- Easy to handle, operate and maintain
- Designed for operation in the inverted position
- H4 duty rated at 30 minutes/300 starts/hour
- Operates with voltage drops up to 10% below name plate rating

- Capacities of up to 3 tons
- Adjustable screw limits provide added reliability
- Standard overload protection offers increased safety
- Minimum 5:1 design ratio
- Zinc plated load chain protects against corrosion
- Grease lubrication in gear case eliminates oil drips on stage

- Hoist motor is completely enclosed in durable protective cast aluminum housing
- Interfaces with all existing controllers and power distros
- Fits in standard road case
- Lifetime warranty
- Each hoist thoroughly inspected and tested to over 125% of rated load prior to shipment
- Meets ASME B30.16, HMI (Hoist Manufacturing Institute), NEC and OSHA standards and regulations
- TUV pending
- CE pending
- Made in U.S.A.
- Manufactured in an ISO 9001 Registered Facility



**CM POLICY STATEMENT FOR LODESTARS USED IN CONJUNCTION WITH FALL PROTECTION EQUIPMENT IN THE ENTERTAINMENT INDUSTRY**

If a fall protection system is used in conjunction with Lodestar hoists, the system must be designed and installed by a qualified person such that malfunction or failure of one hoist's load bearing components does not cause load loss and/or overloading of any other hoist(s) in the system. Also the system must be designed such that the static loading of any hoist does not exceed 50% of the rated capacity. Note that in such a system, hoist performance and function must be monitored visually or with the use of load cells.

<b>* ⚠ WARNING</b>
<b>Overloading and improper use can result in injury.</b>
<p><b>To avoid injury:</b></p> <ul style="list-style-type: none"> <li>• Do not exceed working load limit, load rating or capacity.</li> <li>• Do not use to lift people or loads over people.</li> <li>• Use only alloy chain and attachments for overhead lifting.</li> <li>• Read and follow all instructions.</li> </ul> <p>It is preferred that the load always be tied off with auxiliary chains or cables before access to the area beneath the load is permitted. As an alternative, the system may be designed such that malfunction or failure of one hoist's load bearing components does not cause load loss and/or overloading of any other hoists in the system. Note that in such a system, hoist performance and function must be monitored visually or with the use of load cells.</p>

# Ordering information

**When ordering hoists please specify the following:**

**Capacity**

Available in metric capacities from 1/8 ton through 3 ton (1/2 ton, 1 ton and 2 ton are standard stocked hoists)

**Voltage**

Standard voltages

208 - 240 volt	3 phase	60 hz
208 - 240 volt	1 phase	60 hz
208 - 240 volt	1 phase	50 hz
440 - 480 volt	3 phase	60 hz
110 - 115 volt	1 phase	60 hz
380 - 440 volt	3 phase	50 hz
110 - 115 volt	1 phase	50 hz
575 volt	3 phase	60 hz
575 volt	3 phase	50 hz

Available voltages - contact factory

200 volt	3 phase	50/60 hz
100 volt	1 phase	50 hz
200 volt	1 phase	50 hz
380 volt	3 phase	60 hz

**Speed**

16 fpm (60 hz) and 13.3 fpm (50 hz) is standard for lighting truss, ground support systems, etc., when the loading point is 1 ton or less

8 fpm (60 hz) and 6.5 fpm (50 hz) is standard for speaker clusters, ground support systems, etc., when the loading point is 2 tons or less

Other speeds including 2 speed and variable are available (consult the factory for assistance)

**Lift**

60 ft. is standard but can be furnished in any length required.

**Power cord**

2 1/2 ft. is standard but can be furnished with any length and can be fitted with a connector of your choice

**Control cord**

6' 3" is standard but can be furnished in any length, and furnished with a connector of your choice or with a CM snap action control station for single hoist operation

**Hook style**

360° rotation Latchlok and conventional upper and lower hooks available: Orange on black available – please specify.

**NEMA rating**

Hoist is furnished as standard NEMA 1 (general purpose indoor use)

Factory available to NEMA 3R (rain and sleet resistant) and can be modified by your distributor with weep holes for extended outdoor use

**C.E. stickers**

Lodestars are available that conform to EC Machinery Directive, EC Low Voltage Directive, Harmonized Standards, DIN, VGB8 and IEC Standards

**VGB 70**

Contact factory

**Accessory items**

Chain bags, road boxes, power distros, and multi hoist controllers are all available through your CM distributor

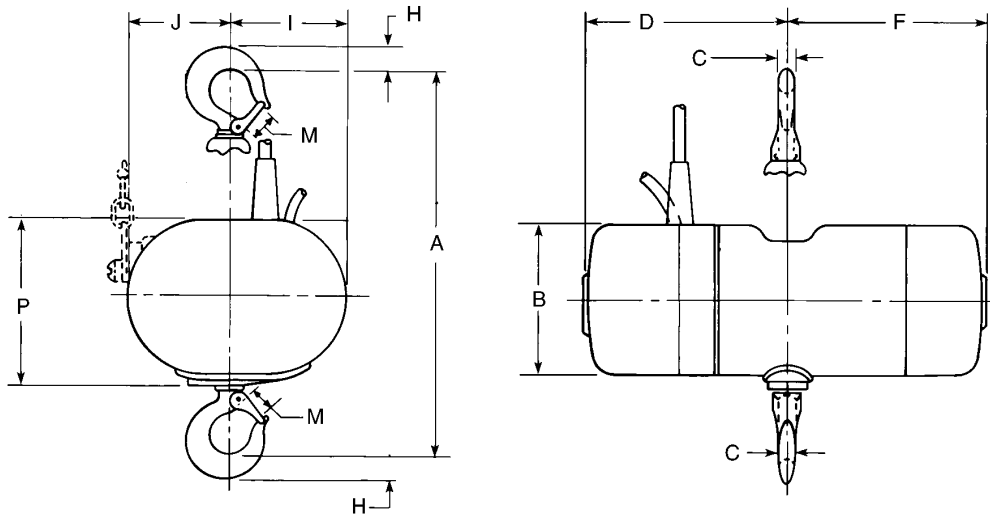

**Clearance dimensions (in.)**

	Lodestar model		
	A, AA, B, C & F	J, JJ, L & LL	R & RR
A	16 <sup>1</sup> / <sub>4</sub>	18 <sup>9</sup> / <sub>16</sub>	24 <sup>1</sup> / <sub>8</sub>
B	6 <sup>1</sup> / <sub>8</sub>	7 <sup>5</sup> / <sub>8</sub>	7 <sup>5</sup> / <sub>8</sub>
C	1 <sup>1</sup> / <sub>16</sub>	7 <sup>7</sup> / <sub>8</sub>	1 <sup>1</sup> / <sub>8</sub>
D	11	9 <sup>1</sup> / <sub>2</sub>	9 <sup>1</sup> / <sub>2</sub>
F	7 <sup>3</sup> / <sub>4</sub>	10 <sup>1</sup> / <sub>16</sub>	10 <sup>1</sup> / <sub>16</sub>
H	1	1 <sup>3</sup> / <sub>16</sub>	1 <sup>1</sup> / <sub>2</sub>
I	4 <sup>13</sup> / <sub>16</sub>	7 <sup>1</sup> / <sub>4</sub>	6 <sup>3</sup> / <sub>16</sub>
J	3 <sup>15</sup> / <sub>16</sub>	5 <sup>7</sup> / <sub>16</sub>	6 <sup>1</sup> / <sub>2</sub>
M	1	1 <sup>1</sup> / <sub>8</sub>	1 <sup>5</sup> / <sub>16</sub>
P	6 <sup>5</sup> / <sub>8</sub>	7 <sup>13</sup> / <sub>16</sub>	7 <sup>13</sup> / <sub>16</sub>

**Hoist specifications - black finish hoist only with 60 ft.\*\* lift** – Suspensions must be ordered separately.

Rated capacity* (tons)	Model	Lifting speed (fpm)	Lift (ft.)	Product code less suspension		Operating voltage	Full load amps	Work rating		
				H.P.				HMI	FEM	ISO
1/4	B	16	60	3140	1/4	115-1-60	5.2	H-4	L4 - 1AM	M-4
1/4	B	16	60	3169	1/4	230/460-3-60	1.8/1.1	H-5	L4 - 1AM	M-4
1/4	C	32	60	3200	1/2	115-1-60	8.0	H-4	L4 - 1AM	M-4
1/4	C	32	60	3201	1/2	230/460-3-60	1.7/1.2	H-5	L4 - 1AM	M-4
1/2	F	16	60	2867S	1/2	115-1-60	8.0	H-4	L4 - 1AM	M-4
1/2	F	16	60	2868S	1/2	230/460-3-60	1.7/1.2	H-5	L4 - 1AM	M-4
1/2	J	32	60	3394	1	115-1-60	17	H-4	L4 - 1AM	M-4
1/2	J	32	60	3482	1	230/460-3-60	3.8/2.3	H-4	L4 - 1AM	M-4
1	L	16	60	3609S	1	115-1-60	17	H-4	L4 - 1AM	M-4
1	L	16	60	3610S	1	230/460-3-60	3.8/2.3	H-4	L4 - 1AM	M-4
2	R	8	60	4238	1	115-1-60	17	H-4	L4 - 1AM	M-4
2	R	8	60	4239	1	230/460-3-60	3.8/2.3	H-4	L4 - 1AM	M-4
2	RR	16	60	4272	2	230/460-3-60	11.3/6	H-4	L3 - 1BM	M-3

Note: All theatrical hoists are shipped with 2 1/2 ft. power and control cords less control station unless otherwise specified. For other lifts, speeds and capacities, contact your nearest CM theatrical distributor.

\*\*For lifts other than 60 ft., contact your nearest CM theatrical distributor.

**CM Lodestar hook suspensions with black finish**

Model	Conventional rigid hook	Conventional swivel hook	Latchlok rigid hook	Latchlok swivel hook
AA - F	2998	2999	2998E	2999E
J - LL	3631	3624	3631E	3624E
R & RR	3634	3600	3634E	3600E

Note: For other hook suspensions or special configurations, contact factory

# CM Alloy Latchlok hooks

Latchlok hooks combine innovative design and solid alloy steel. I-beam construction offers more reliable performance than any other hook on the market. Features include:

- One-hand operation and recessed push-button thumb release for smooth and dependable opening
- Hook remains locked until released by the operator, even if chain goes slack
- Sturdy forged heat treated I-beam construction for strong yet lightweight hooks
- Made in U.S.A.

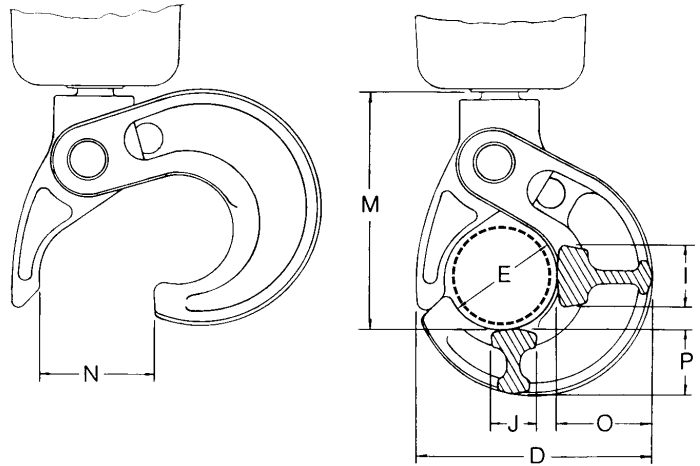

## Specifications

Hoist	Hoist model	Clearance dimensions (in.)								Change in standard headroom (in.)	
		D	E	I	J	M	N	O	P		
Lodestar	A, AA, B, C & F	3 <sup>7</sup> / <sub>16</sub>	1 <sup>3</sup> / <sub>4</sub>	1 <sup>5</sup> / <sub>16</sub>	1 <sup>3</sup> / <sub>16</sub>	3 <sup>5</sup> / <sub>8</sub>	1 <sup>3</sup> / <sub>8</sub>	1 <sup>5</sup> / <sub>16</sub>	1	1	
	E & H	3 <sup>7</sup> / <sub>16</sub>	1 <sup>3</sup> / <sub>4</sub>	1 <sup>5</sup> / <sub>16</sub>	1 <sup>3</sup> / <sub>16</sub>	3 <sup>5</sup> / <sub>8</sub>	1 <sup>3</sup> / <sub>8</sub>	1 <sup>5</sup> / <sub>16</sub>	1	1 <sup>1</sup> / <sub>16</sub>	
	Upper	J, JJ, L & LL	3 <sup>7</sup> / <sub>16</sub>	1 <sup>3</sup> / <sub>4</sub>	1 <sup>5</sup> / <sub>16</sub>	1 <sup>3</sup> / <sub>16</sub>	3 <sup>5</sup> / <sub>8</sub>	1 <sup>3</sup> / <sub>8</sub>	1 <sup>5</sup> / <sub>16</sub>	1	1 <sup>1</sup> / <sub>16</sub>
	R & RR	4 <sup>1</sup> / <sub>16</sub>	1 <sup>7</sup> / <sub>8</sub>	1 <sup>1</sup> / <sub>8</sub>	5 <sup>5</sup> / <sub>8</sub>	4 <sup>9</sup> / <sub>16</sub>	1 <sup>3</sup> / <sub>4</sub>	1 <sup>5</sup> / <sub>8</sub>	1 <sup>1</sup> / <sub>8</sub>	1 <sup>5</sup> / <sub>16</sub>	
Lower	R & RRT	4 <sup>3</sup> / <sub>4</sub>	2 <sup>1</sup> / <sub>16</sub>	1 <sup>11</sup> / <sub>16</sub>	1 <sup>3</sup> / <sub>8</sub>	5 <sup>11</sup> / <sub>16</sub>	2 <sup>3</sup> / <sub>16</sub>	1 <sup>5</sup> / <sub>8</sub>	1 <sup>3</sup> / <sub>8</sub>	2 <sup>1</sup> / <sub>16</sub>	
	A, AA, B, C & F	3 <sup>7</sup> / <sub>16</sub>	1 <sup>3</sup> / <sub>4</sub>	1 <sup>5</sup> / <sub>16</sub>	1 <sup>3</sup> / <sub>16</sub>	3 <sup>5</sup> / <sub>8</sub>	1 <sup>3</sup> / <sub>8</sub>	1 <sup>5</sup> / <sub>16</sub>	1	1	
	E & H	3 <sup>7</sup> / <sub>16</sub>	1 <sup>3</sup> / <sub>4</sub>	1 <sup>5</sup> / <sub>16</sub>	1 <sup>3</sup> / <sub>16</sub>	3 <sup>5</sup> / <sub>8</sub>	1 <sup>3</sup> / <sub>8</sub>	1 <sup>5</sup> / <sub>16</sub>	1	1 <sup>1</sup> / <sub>16</sub>	
	J, JJ, L & LL	3 <sup>7</sup> / <sub>16</sub>	1 <sup>3</sup> / <sub>4</sub>	1 <sup>5</sup> / <sub>16</sub>	1 <sup>3</sup> / <sub>16</sub>	3 <sup>5</sup> / <sub>8</sub>	1 <sup>3</sup> / <sub>8</sub>	1 <sup>5</sup> / <sub>16</sub>	1	1 <sup>1</sup> / <sub>16</sub>	
	R & RR	4 <sup>1</sup> / <sub>16</sub>	1 <sup>7</sup> / <sub>8</sub>	1 <sup>1</sup> / <sub>8</sub>	5 <sup>5</sup> / <sub>8</sub>	4 <sup>1</sup> / <sub>2</sub>	1 <sup>3</sup> / <sub>4</sub>	1 <sup>5</sup> / <sub>8</sub>	1 <sup>1</sup> / <sub>8</sub>	7 <sup>7</sup> / <sub>8</sub>	
	RT & RRT	4 <sup>3</sup> / <sub>4</sub>	2 <sup>1</sup> / <sub>16</sub>	1 <sup>11</sup> / <sub>16</sub>	1 <sup>3</sup> / <sub>8</sub>	5 <sup>11</sup> / <sub>16</sub>	2 <sup>3</sup> / <sub>16</sub>	1 <sup>5</sup> / <sub>8</sub>	1 <sup>3</sup> / <sub>8</sub>	2 <sup>1</sup> / <sub>16</sub>	

## CM Lodestar Latchlok lower hook

Available for models A, AA, B, C, F, J, JJ, L, LL, R, RR, RT & RRT. CM product code must be specified when order is placed

<b>* ⚠ WARNING</b>
<b>Overloading and improper use can result in injury.</b>
<p><b>To avoid injury:</b></p> <ul style="list-style-type: none"> <li>• Do not exceed working load limit, load rating or capacity.</li> <li>• Do not use to lift people or loads over people.</li> <li>• Use only alloy chain for overhead lifting.</li> <li>• Read and follow all instructions.</li> </ul>

**Rugged control station (optional)**

Completely sealed control station is rated NEMA 4 for:

- Impact-resistant control station for extreme durability
- Snap-action contacts for positive control and reduced downtime caused by electrical arcing
- Internal strain relief made from high-strength aircraft cable prevents control cable from being pulled out of hoist or control station
- Low voltage (120 volts) control circuit



**Heavy-duty hoist motor with regenerative braking**

Hoist motor designed for industrial applications. Integral motor design:

- Meets or exceeds HMI (Hoist Manufacturing Institute) duty cycle rating for heavy duty service (H4)
- Provides efficiency and cooler operation for longer life
- Gives substantially higher duty cycle for greater productivity
- Uses efficient regenerative braking that avoids heat generation or power reduction in power train
- Single speed or 3:1 two speed option
- 30 minute rated motor

**Simple installation and service**

Accessible design makes the CM Lodestar hoist the easiest electric chain hoist to install and service, featuring:

- Completely identified wiring for fast, simple connections
- Easy access to working parts for fast troubleshooting and repair
- Reduced maintenance for less downtime, greater productivity
- Three phase single speed models offer simple voltage change for adaptability to different applications
- Easy voltage change makes any single speed three phase Lodestar usable on either 230 or 460 volts — eight quick-connect terminals are transferred in seconds

**Solid state starting switch**

115 volt single phase Lodestar hoists are equipped with an instant reverse, solid-state switch that:

- Eliminates the mechanical centrifugal mechanism and reversing switch, the most common sources of unscheduled maintenance and motor burnout in single phase hoists
- Reduces stress on starting capacitor with elimination of moving parts in motor start/reverse switch
- Improves electrical reliability, reducing downtime

**Cast aluminum alloy housing and covers**

Integral frame and housing design provides lightweight, low profile hoist for:

- Minimum headroom/maximum lift
- Better heat dissipation from motor, brake and gear train for increased productivity
- Factory weatherproofing available for use in adverse conditions
- Acid-resistant, durable powder coated finish is standard



**Hardened steel chain guides**

Chain guides completely surround the liftwheel to:

- Maintain proper load chain fit
- Jam-resistant chain feed for reduced maintenance and downtime

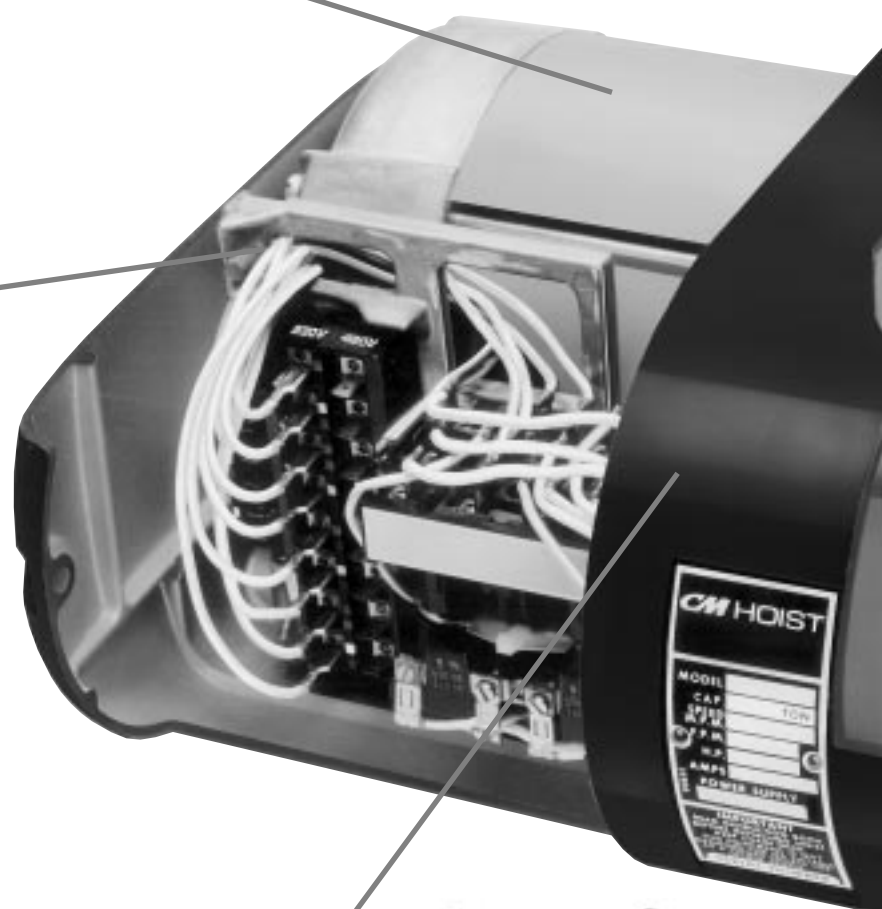

**Machined alloy steel heat treated liftwheel**

- Precision machined and heat treated for additional strength and durability
- Smooth, reliable operation
- Reduced wear for longer liftwheel, chain guide and chain life
- True vertical lift

**Lifetime lubricated machined and heat treated gears**

- Simple spur and helical triple reduction gear system operates in grease and provides:
- Superior service and maintenance characteristics
  - Smooth operation/reduced wear
  - No oil changes required
  - No oil contamination of loads or work area
  - No troublesome seals to leak or replace
  - Lifetime lubricated ball bearings support load bearing, rotating shafts

**Disc type electric hoist brake**

Heavy-duty electric hoist brake provides positive load control. Performance features:

- Securely holds load, even in event of power or phase failure
- Eliminates heat buildup found in mechanical type braking systems
- Requires little maintenance, few adjustments
- All 1/2 - 2 horsepower Lodestars

**Extra long lift adjustable screw limit switches are standard equipment**

Tailor hoist operation to suit your specific application. Adjustable screw limit switches:

- Come factory set for full hook travel, but easily adjust for any desired position
- Prevent dangerous overtravel of hoist load chain
- Holds limit settings even after engaging Protector



**Drop forged, heat treated hooks and special lifting chain**

Superior quality overhead lifting chain, plus forged suspension and load hooks provide:

- Higher strength for lifting confidence
- Greater durability for longer life
- CM Hoistaloy load chain for maximum strength and wear resistance.

**Standard overload protection**

CM Lodestar Protector takes the worry out of hoist operation through:

- Positive overload protection that prevents lifting of dangerous overloads
- Extra security in the event of limit switch misadjustment or misphasing of power leads

**\*  WARNING**

Overloading and improper use can result in injury.

See page 7



**Industrial specifications — single speed — orange paint**

Rated capacity* (tons)	Standard lift (ft.)	Lift speed** (F.P.M.)	Motor H.P.	Model	Reeving	Product code† less suspension		Approximate shipping weight (lbs.)
						115-1-60	230/460-3-60	
1/8	10	32	1/4	A	1	2702	2705	60
	10	60	1/2	AA	1	2712	2715	66
	15	32	1/4	A	1	3101	3103	64
	15	60	1/2	AA	1	3111	3113	70
	20	32	1/4	A	1	3102	3104	68
	20	60	1/2	AA	1	3112	3114	74
1/4	10	16	1/4	B	1	2722	2725	60
	10	32	1/2	C	1	2732	2735	66
	15	16	1/4	B	1	3121	3123	64
	15	32	1/2	C	1	3131	3133	70
	20	16	1/4	B	1	3122	3124	68
	20	32	1/2	C	1	3132	3134	74
1/2	10	8	1/4	E	2	2742	2745	69
	10	16	1/2	F	1	2752	2755	66
	10	32	1	J	1	3512	3515	110
	10	64	2	JJ	1	—	3545	117
	15	8	1/4	E	2	3141	3143	76
	15	16	1/2	F	1	3151	3153	70
	15	32	1	J	1	4212	4214	116
	15	64	2	JJ	1	—	4244	123
	20	8	1/4	E	2	3142	3144	83
	20	16	1/2	F	1	3152	3154	74
1	20	32	1	J	1	4213	4215	121
	20	64	2	JJ	1	—	4245	128
	10	8	1/2	H	2	2762	2765	75
	10	16	1	L	1	3522	3525	110
	10	32	2	LL	1	—	3555	117
	15	8	1/2	H	2	3161	3163	82
	15	16	1	L	1	4222	4224	116
	15	32	2	LL	1	—	4254	123
	20	8	1/2	H	2	3162	3164	89
	20	16	1	L	1	4223	4225	121
2	20	32	2	LL	1	—	4255	128
	10	8	1	R	2	3532	3535	130
	10	16	2	RR	2	—	3565	137
	15	8	1	R	2	4232	4234	140
	15	16	2	RR	2	—	4264	147
	20	8	1	R	2	4233	4235	150
3	20	16	2	RR	2	—	4265	157
	10	5.5	1	RT	3	9501	9505	155
	10	11	2	RRT	3	—	9508	162
	15	5.5	1	RT	3	9502	9506	169
	15	11	2	RRT	3	—	9509	176
	20	5.5	1	RT	3	9503	9507	183
20	11	2	RRT	3	—	9510	190	

† Single speed hoist factory wired 460V, convertible to 230V

\*\*Lifting speed is 5/6 the listed speed for 50 hz

Note: Black finish must be specified on order

**Industrial specifications — two speed — orange paint**

Rated capacity* (tons)	Standard lift (ft.)	Lift speed** (F.P.M.)	Motor H.P.	Model	Reeving	Product code† less suspension		Approximate shipping weight (lbs.)
						230-3-60	460-3-60	
1/8	10	10/32	1/4	A2	1	2707	2708	70
	10	20/60	1/2	AA2	1	2717	2718	74
1/4	10	5/16	1/4	B2	1	2727	2728	70
	10	10/32	1/2	C2	1	2737	2738	74
1/2	10	2.5/8	1/4	E2	2	2747	2748	79
	10	5/16	1/2	F2	1	2757	2758	74
	10	10/32	1	J2	1	3502	3503	116
	10	21/64	2	JJ2	1	3549	3550	130
1	10	2.5/8	1/2	H2	2	2767	2768	83
	10	5/16	1	L2	1	3504	3505	116
	10	10/32	2	LL2	1	3553	3554	130
2	10	2.5/8	1	R2	2	3506	3507	136
	10	5/16	2	RR2	2	3561	3562	150
3	10	1.75/5.5	1	RT2	3	9511	9513	161
	10	3.5/11	2	RRT2	3	9512	9514	175

\*\*Lifting speed is 5/6 the listed speed for 50 hz

†Specify voltage 230 or 460

Note: Black finish must be specified on order

**Industrial suspension specifications — orange paint**

Type	Product code	Models	Approximate weight (lbs.)
Swivel hook	2792	A-AA-B-C-F	2
Swivel hook	2793	E-H	4
Swivel hook	3661	J-L-JJ-LL	4
Swivel hook	3660	R-RR	9
Swivel hook	9557	RT-RRT	8
Rigid lug for low head trolley	2778	A-AA-B-C-F	2
Rigid lug for low head trolley	2779	E-H	4
Rigid lug for low head trolley	3677	J-L-JJ-LL	4
Rigid lug for low head trolley	3668	R-RR	6
Rigid lug for low head trolley	9561	RT-RRT	9
Rigid hook	2788	A-AA-B-C-F	2
Rigid hook	2789	E-H	3
Rigid hook	3651	J-L-JJ-LL	4
Rigid hook	3658	R-RR	6
Rigid hook	9559	RT-RRT	9

Note: 3 ton lug suspension prevents hoist from rotating but allows hoist to articulate below trolley

Note: Black finish must be specified on order

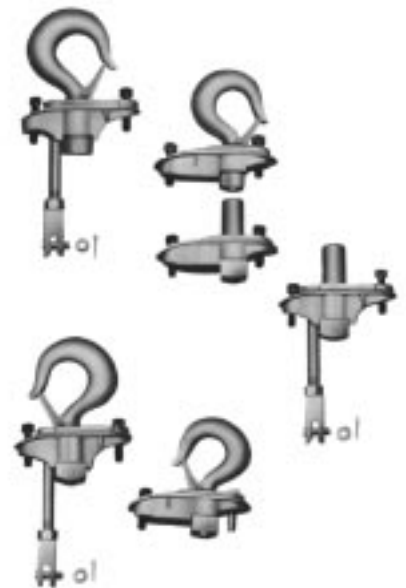

<b>* ⚠ WARNING</b>
<b>Overloading and improper use can result in injury.</b>
<p><b>To avoid injury:</b></p> <ul style="list-style-type: none"> <li>• Do not exceed working load limit, load rating or capacity.</li> <li>• Do not use to lift people or loads over people.</li> <li>• Use only alloy chain for overhead lifting.</li> <li>• Read and follow all instructions.</li> </ul>



# Lodestar with hook suspension

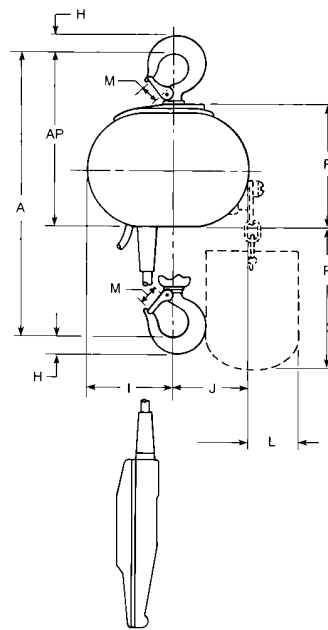
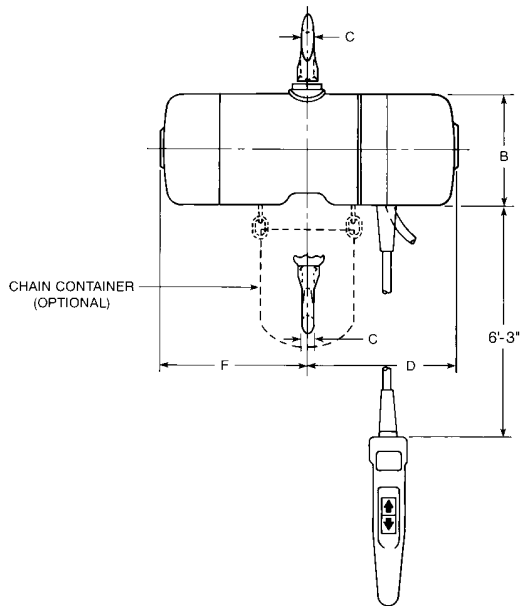

## Clearance dimensions (in.)

Lodestar models	A,B,C,F and AA	E and H	J, L, JJ and LL	R	RR	RT and RRT
A	16 <sup>1</sup> / <sub>4</sub>	19 <sup>5</sup> / <sub>8</sub>	18 <sup>9</sup> / <sub>16</sub>	24 <sup>1</sup> / <sub>8</sub>	24 <sup>1</sup> / <sub>8</sub>	29 <sup>9</sup> / <sub>16</sub>
B	6 <sup>1</sup> / <sub>8</sub>	6 <sup>1</sup> / <sub>8</sub>	7 <sup>5</sup> / <sub>8</sub>	7 <sup>5</sup> / <sub>8</sub>	7 <sup>5</sup> / <sub>8</sub>	7 <sup>5</sup> / <sub>8</sub>
C	1 <sup>1</sup> / <sub>16</sub>	7 <sup>7</sup> / <sub>8</sub>	7 <sup>7</sup> / <sub>8</sub>	1 <sup>1</sup> / <sub>8</sub>	1 <sup>1</sup> / <sub>8</sub>	1 <sup>1</sup> / <sub>8</sub>
D	11	11	9 <sup>1</sup> / <sub>2</sub>	9 <sup>1</sup> / <sub>2</sub>	9 <sup>1</sup> / <sub>2</sub>	9 <sup>1</sup> / <sub>2</sub>
F	7 <sup>3</sup> / <sub>4</sub>	7 <sup>3</sup> / <sub>4</sub>	10 <sup>11</sup> / <sub>16</sub>	10 <sup>11</sup> / <sub>16</sub>	10 <sup>11</sup> / <sub>16</sub>	10 <sup>11</sup> / <sub>16</sub>
H	1	1 <sup>3</sup> / <sub>16</sub>	1 <sup>3</sup> / <sub>16</sub>	1 <sup>1</sup> / <sub>2</sub>	1 <sup>1</sup> / <sub>2</sub>	1 <sup>1</sup> / <sub>2</sub>
I	4 <sup>13</sup> / <sub>16</sub>	3 <sup>7</sup> / <sub>8</sub>	7 <sup>1</sup> / <sub>4</sub>	6 <sup>3</sup> / <sub>16</sub>	6 <sup>3</sup> / <sub>16</sub>	6 <sup>3</sup> / <sub>16</sub>
J	3 <sup>15</sup> / <sub>16</sub>	4 <sup>7</sup> / <sub>8</sub>	5 <sup>7</sup> / <sub>16</sub>	6 <sup>1</sup> / <sub>2</sub>	6 <sup>1</sup> / <sub>2</sub>	6 <sup>1</sup> / <sub>2</sub>
L	1 <sup>11</sup> / <sub>16</sub>	1 <sup>11</sup> / <sub>16</sub>	7 <sup>7</sup> / <sub>16</sub>	7 <sup>7</sup> / <sub>16</sub>	7 <sup>7</sup> / <sub>16</sub>	7 <sup>7</sup> / <sub>16</sub>
M	1	1 <sup>1</sup> / <sub>8</sub>	1 <sup>1</sup> / <sub>8</sub>	1 <sup>5</sup> / <sub>16</sub>	1 <sup>5</sup> / <sub>16</sub>	1 <sup>5</sup> / <sub>16</sub>
P	6 <sup>5</sup> / <sub>8</sub>	6 <sup>9</sup> / <sub>16</sub>	7 <sup>13</sup> / <sub>16</sub>	7 <sup>13</sup> / <sub>16</sub>	7 <sup>13</sup> / <sub>16</sub>	7 <sup>13</sup> / <sub>16</sub>
R*	9 <sup>7</sup> / <sub>8</sub>	12 <sup>7</sup> / <sub>8</sub>	12 <sup>7</sup> / <sub>8</sub>	18 <sup>7</sup> / <sub>8</sub>	18 <sup>7</sup> / <sub>8</sub>	24 <sup>7</sup> / <sub>8</sub>
AP	9 <sup>1</sup> / <sub>4</sub>	9 <sup>9</sup> / <sub>16</sub>	10 <sup>11</sup> / <sub>16</sub>	11 <sup>3</sup> / <sub>16</sub>	11 <sup>3</sup> / <sub>16</sub>	12 <sup>9</sup> / <sub>16</sub>

\* Based on 10 ft. lift and increases proportionately with longer lifts

## \* ⚠ WARNING

**Overloading and improper use can result in injury.**

### To avoid injury:

- Do not exceed working load limit, load rating or capacity.
- Do not use to lift people or loads over people.
- Use only alloy chain for overhead lifting.
- Read and follow all instructions.

# Lodestar with Series 635 low headroom trolley

Designed for attachment by use of rigid lug suspension to give extra low headroom. Self-aligning steel side frames and hardened steel wheels with crowned tread and precision ball bearings. (Flat black powder coat finish)

## Clearance dimensions (in.)

Lodestar models	A,B,C,F and AA	E and H	J, L, JJ and LL	R	RR	RT and RRT
A	16 <sup>5</sup> / <sub>16</sub>	19 <sup>1</sup> / <sub>4</sub>	18 <sup>1</sup> / <sub>4</sub>	23 <sup>3</sup> / <sub>4</sub>	23 <sup>3</sup> / <sub>4</sub>	29 <sup>9</sup> / <sub>16</sub>
B	6 <sup>1</sup> / <sub>8</sub>	6 <sup>1</sup> / <sub>8</sub>	7 <sup>5</sup> / <sub>8</sub>	7 <sup>5</sup> / <sub>8</sub>	7 <sup>5</sup> / <sub>8</sub>	7 <sup>5</sup> / <sub>8</sub>
C	1 <sup>1</sup> / <sub>16</sub>	7 <sup>7</sup> / <sub>8</sub>	7 <sup>7</sup> / <sub>8</sub>	1 <sup>1</sup> / <sub>8</sub>	1 <sup>1</sup> / <sub>8</sub>	1 <sup>1</sup> / <sub>8</sub>
D	11	11	9 <sup>1</sup> / <sub>2</sub>	9 <sup>1</sup> / <sub>2</sub>	9 <sup>1</sup> / <sub>2</sub>	9 <sup>1</sup> / <sub>2</sub>
F	7 <sup>3</sup> / <sub>4</sub>	7 <sup>3</sup> / <sub>4</sub>	10 <sup>11</sup> / <sub>16</sub>	10 <sup>11</sup> / <sub>16</sub>	10 <sup>11</sup> / <sub>16</sub>	10 <sup>11</sup> / <sub>16</sub>
H	1	1 <sup>3</sup> / <sub>16</sub>	1 <sup>3</sup> / <sub>16</sub>	1 <sup>1</sup> / <sub>2</sub>	1 <sup>1</sup> / <sub>2</sub>	1 <sup>1</sup> / <sub>2</sub>
I	4 <sup>13</sup> / <sub>16</sub>	3 <sup>7</sup> / <sub>8</sub>	7 <sup>1</sup> / <sub>4</sub>	6 <sup>3</sup> / <sub>16</sub>	6 <sup>3</sup> / <sub>16</sub>	6 <sup>3</sup> / <sub>16</sub>
J	3 <sup>15</sup> / <sub>16</sub>	4 <sup>7</sup> / <sub>8</sub>	5 <sup>7</sup> / <sub>16</sub>	6 <sup>1</sup> / <sub>2</sub>	6 <sup>1</sup> / <sub>2</sub>	6 <sup>1</sup> / <sub>2</sub>
L	1 <sup>11</sup> / <sub>16</sub>	1 <sup>11</sup> / <sub>16</sub>	7 <sup>1</sup> / <sub>16</sub>	7 <sup>1</sup> / <sub>16</sub>	7 <sup>1</sup> / <sub>16</sub>	7 <sup>1</sup> / <sub>16</sub>
M	1	1 <sup>1</sup> / <sub>8</sub>	1 <sup>1</sup> / <sub>8</sub>	1 <sup>5</sup> / <sub>16</sub>	1 <sup>5</sup> / <sub>16</sub>	1 <sup>5</sup> / <sub>16</sub>
RT†	9 <sup>7</sup> / <sub>8</sub>	12 <sup>7</sup> / <sub>8</sub>	12 <sup>7</sup> / <sub>8</sub>	18 <sup>7</sup> / <sub>8</sub>	18 <sup>7</sup> / <sub>8</sub>	24 <sup>7</sup> / <sub>8</sub>
T	1 <sup>3</sup> / <sub>16</sub>	1 <sup>3</sup> / <sub>16</sub>	1 <sup>3</sup> / <sub>16</sub>	7 <sup>7</sup> / <sub>8</sub>	7 <sup>7</sup> / <sub>8</sub>	5 <sup>1</sup> / <sub>16</sub>
W	3	3	3	3 <sup>5</sup> / <sub>8</sub>	3 <sup>5</sup> / <sub>8</sub>	4 <sup>1</sup> / <sub>8</sub>
X	5 <sup>1</sup> / <sub>16</sub>	5 <sup>1</sup> / <sub>16</sub>	5 <sup>1</sup> / <sub>16</sub>	1 <sup>1</sup> / <sub>2</sub>	1 <sup>1</sup> / <sub>2</sub>	9 <sup>1</sup> / <sub>16</sub>
Y	1 <sup>1</sup> / <sub>16</sub>	1 <sup>1</sup> / <sub>16</sub>	1 <sup>1</sup> / <sub>16</sub>	3 <sup>1</sup> / <sub>16</sub>	3 <sup>1</sup> / <sub>16</sub>	2 <sup>5</sup> / <sub>8</sub>
AD	9 <sup>3</sup> / <sub>4</sub>	9 <sup>3</sup> / <sub>4</sub>	9 <sup>3</sup> / <sub>4</sub>	13	13	12 <sup>1</sup> / <sub>2</sub>
AF	5	5	5	6	6	6
AG	3 <sup>1</sup> / <sub>8</sub>	3 <sup>1</sup> / <sub>8</sub>	3 <sup>1</sup> / <sub>8</sub>	4 <sup>3</sup> / <sub>4</sub>	4 <sup>3</sup> / <sub>4</sub>	4
AI	4 <sup>5</sup> / <sub>8</sub>	4 <sup>5</sup> / <sub>8</sub>	4 <sup>5</sup> / <sub>8</sub>	5	5	5 <sup>1</sup> / <sub>2</sub>
AJ	9 <sup>3</sup> / <sub>16</sub>	9 <sup>3</sup> / <sub>16</sub>	10 <sup>3</sup> / <sub>8</sub>	10 <sup>13</sup> / <sub>16</sub>	10 <sup>13</sup> / <sub>16</sub>	13 <sup>1</sup> / <sub>8</sub>

† Based on 10 ft. lift and increases proportionately with longer lifts

Dimensions T, W, X, Y, AI, and AJ are based on minimum beams and will vary proportionately for larger beams. 6'-3" drop of control station is for 10 foot lift hoist and increases proportionately for longer lifts.

## Suspension specifications

Type	Product code	Models
Rigid lug for low head trolley	2778	A-AA-B-C-F
	2779	E-H
	3677	J-L-JJ-LL
	3668	R-RR
	9561	RT-RRT

Note: 3 ton lug suspension prevents hoist from rotating but allows hoist to articulate below trolley

## Specifications – Low Headroom Trolley

Rated capacity* (tons)	Product code	Models	Std. range of adjust. Am. standard S-beams		Tread diameter (in.)	Minimum radius curve (in.)	Approximate shipping weight (lbs.)
			Depth (in.)	Flange width (in.)			
1/8 to 1	3575	A – LL	4 – 15	2 <sup>5</sup> / <sub>8</sub> – 5 <sup>5</sup> / <sub>8</sub>	3 <sup>1</sup> / <sub>8</sub>	24	22
2	3569	R – RR	6 – 18	3 <sup>3</sup> / <sub>8</sub> – 6	4 <sup>3</sup> / <sub>4</sub>	24	52
3	9576	RT – RRT	8 – 15	4 – 5 <sup>5</sup> / <sub>8</sub>	4 <sup>3</sup> / <sub>4</sub>	30	58

Note: Rigid lug suspension required for attaching to hoist. Apply for other than standard beam adjustment.

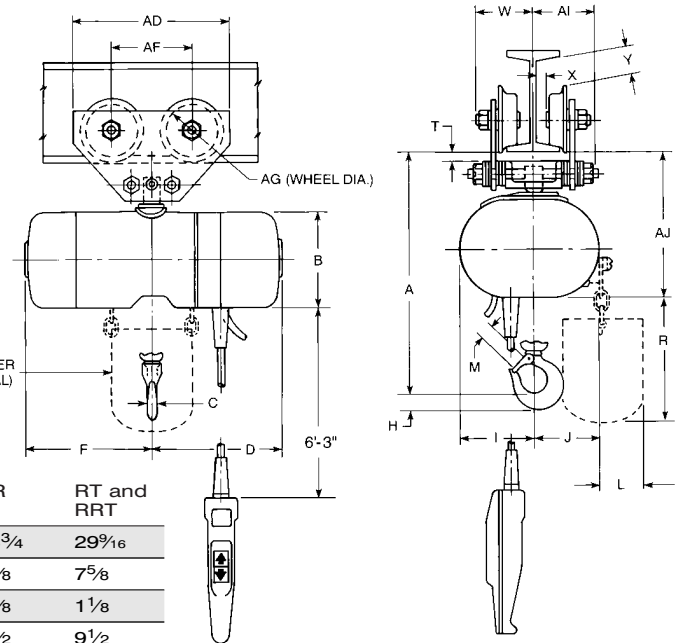

Beam end stop omitted for picture clarity  
For beam sizes other than those listed, contact factory

# Lodestar with Series 635 motor driven trolley

The motor driven trolley is self-contained and supplied with independent wiring and controls, including a four-direction control station, ready for attachment to any model by means of lug suspension. Provides easier, speedier and more efficient load transportation. (Flat black powder coat finish)

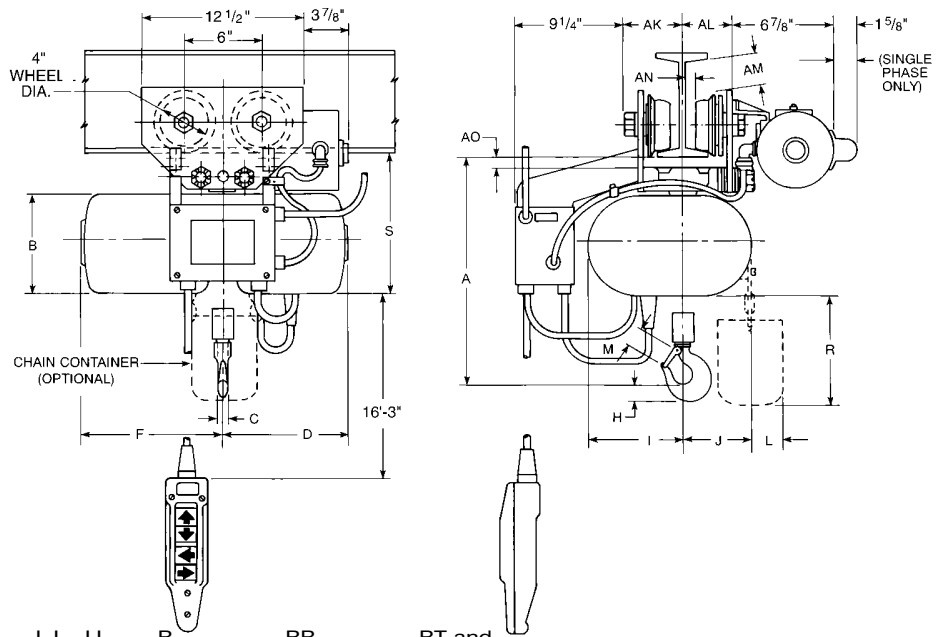

### Clearance dimensions (in.)

Lodestar model†	A,B,C,F and AA	E and H	J, L, JJ and LL	R	RR	RT and RRT
A	16 <sup>13</sup> / <sub>16</sub>	19 <sup>3</sup> / <sub>4</sub>	18 <sup>1</sup> / <sub>2</sub>	23 <sup>3</sup> / <sub>4</sub>	23 <sup>3</sup> / <sub>4</sub>	30 <sup>1</sup> / <sub>8</sub>
B	6 <sup>1</sup> / <sub>8</sub>	6 <sup>1</sup> / <sub>8</sub>	7 <sup>5</sup> / <sub>8</sub>	7 <sup>5</sup> / <sub>8</sub>	7 <sup>5</sup> / <sub>8</sub>	7 <sup>5</sup> / <sub>8</sub>
C	1 <sup>1</sup> / <sub>16</sub>	7 <sup>7</sup> / <sub>8</sub>	7 <sup>7</sup> / <sub>8</sub>	1 <sup>1</sup> / <sub>8</sub>	1 <sup>1</sup> / <sub>8</sub>	1 <sup>1</sup> / <sub>8</sub>
D	11	11	9 <sup>1</sup> / <sub>2</sub>	9 <sup>1</sup> / <sub>2</sub>	9 <sup>1</sup> / <sub>2</sub>	9 <sup>1</sup> / <sub>2</sub>
F	7 <sup>3</sup> / <sub>4</sub>	7 <sup>3</sup> / <sub>4</sub>	10 <sup>11</sup> / <sub>16</sub>	10 <sup>11</sup> / <sub>16</sub>	10 <sup>11</sup> / <sub>16</sub>	10 <sup>11</sup> / <sub>16</sub>
H	1	1 <sup>9</sup> / <sub>16</sub>	1 <sup>3</sup> / <sub>16</sub>	1 <sup>1</sup> / <sub>2</sub>	1 <sup>1</sup> / <sub>2</sub>	1 <sup>1</sup> / <sub>2</sub>
I	4 <sup>13</sup> / <sub>16</sub>	3 <sup>7</sup> / <sub>8</sub>	7 <sup>1</sup> / <sub>4</sub>	6 <sup>3</sup> / <sub>16</sub>	6 <sup>3</sup> / <sub>16</sub>	6 <sup>3</sup> / <sub>16</sub>
J	3 <sup>15</sup> / <sub>16</sub>	4 <sup>7</sup> / <sub>8</sub>	5 <sup>7</sup> / <sub>16</sub>	6 <sup>1</sup> / <sub>2</sub>	6 <sup>1</sup> / <sub>2</sub>	6 <sup>1</sup> / <sub>2</sub>
L	1 <sup>11</sup> / <sub>16</sub>	1 <sup>11</sup> / <sub>16</sub>	7 <sup>7</sup> / <sub>16</sub>	7 <sup>7</sup> / <sub>16</sub>	7 <sup>7</sup> / <sub>16</sub>	7 <sup>7</sup> / <sub>16</sub>
M	1	1 <sup>1</sup> / <sub>8</sub>	1 <sup>1</sup> / <sub>8</sub>	1 <sup>5</sup> / <sub>16</sub>	1 <sup>5</sup> / <sub>16</sub>	1 <sup>5</sup> / <sub>16</sub>
R**	9 <sup>7</sup> / <sub>8</sub>	12 <sup>7</sup> / <sub>8</sub>	12 <sup>7</sup> / <sub>8</sub>	18 <sup>7</sup> / <sub>8</sub>	18 <sup>7</sup> / <sub>8</sub>	24 <sup>7</sup> / <sub>8</sub>
S	9 <sup>11</sup> / <sub>16</sub>	9 <sup>11</sup> / <sub>16</sub>	10 <sup>5</sup> / <sub>8</sub>	10 <sup>13</sup> / <sub>16</sub>	10 <sup>13</sup> / <sub>16</sub>	13 <sup>1</sup> / <sub>8</sub>
AK	3 <sup>3</sup> / <sub>4</sub>	3 <sup>3</sup> / <sub>4</sub>	3 <sup>3</sup> / <sub>4</sub>	3 <sup>3</sup> / <sub>4</sub>	3 <sup>3</sup> / <sub>4</sub>	4 <sup>1</sup> / <sub>4</sub>
AL	3 <sup>1</sup> / <sub>4</sub>	3 <sup>1</sup> / <sub>4</sub>	3 <sup>1</sup> / <sub>4</sub>	3 <sup>1</sup> / <sub>4</sub>	3 <sup>1</sup> / <sub>4</sub>	3 <sup>3</sup> / <sub>4</sub>
AM	5 <sup>5</sup> / <sub>8</sub>	5 <sup>5</sup> / <sub>8</sub>	5 <sup>5</sup> / <sub>8</sub>	5 <sup>5</sup> / <sub>8</sub>	5 <sup>5</sup> / <sub>8</sub>	2 <sup>5</sup> / <sub>8</sub>
AN	5 <sup>5</sup> / <sub>16</sub>	5 <sup>5</sup> / <sub>16</sub>	5 <sup>5</sup> / <sub>16</sub>	5 <sup>5</sup> / <sub>16</sub>	5 <sup>5</sup> / <sub>16</sub>	9 <sup>9</sup> / <sub>16</sub>
AO	7 <sup>7</sup> / <sub>8</sub>	7 <sup>7</sup> / <sub>8</sub>	7 <sup>7</sup> / <sub>8</sub>	7 <sup>7</sup> / <sub>8</sub>	7 <sup>7</sup> / <sub>8</sub>	1

\*\*Based on 10 ft. lift and increases proportionately with longer lifts

Dimensions S, AK, AL, AM, and AO are based on minimum beams and will vary proportionately for larger beams. 16'-3" drop of control station is for 20 foot lift hoist.

For beam sizes other than those listed, contact factory.

†Note: Rigid lug suspension required for attaching to hoist

### Suspension specifications

Type	Product code	Models
Rigid lug for motor driven trolley	2992	A-AA-B-C-F
Rigid lug for motor driven trolley	2993	E-H
Rigid lug for motor driven trolley	3679	J-L-JJ-LL
Rigid lug for motor driven trolley	3668	R-RR
Rigid lug for motor driven trolley	9561	RT-RRT

Note: Beam end stop omitted for picture clarity



**Specifications — motor driven trolley**

Rated capacity* (tons)	Product code	For use with model	Power supply	Standard travel speed (F.P.M.)	Motor H.P.	Std. range of adj. Am. std. S-beams		Minimum radius curve (in.)	Approx. shipping weight (lbs.)
						Depth (in.)	Flange width (in.)		
1/8 - 2	3670	A-RR	115-1-60	75	1/4	6 – 15	3 3/8 – 5 5/8	30	118
1/8 - 2	3671	A-RR	230-3-60	75	1/4	6 – 15	3 3/8 – 5 5/8	30	118
1/8 - 2	3672	A-RR	460-3-60	75	1/4	6 – 15	3 3/8 – 5 5/8	30	118
3	9577	RT-RRT	115-1-60	75	1/4	8 – 15	4 – 5 5/8	30	120
3	9578	RT-RRT	230-3-60	75	1/4	8 – 15	4 – 5 5/8	30	120
3	9579	RT-RRT	460-3-60	75	1/4	8 – 15	4 – 5 5/8	30	120
1/8 - 2	9315	A-RR	115-1-60	30	1/4	6 – 15	3 3/8 – 5 5/8	30	113
1/8 - 2	9316	A-RR	230-3-60	30	1/4	6 – 15	3 3/8 – 5 5/8	30	113
1/8 - 2	9317	A-RR	460-3-60	30	1/4	6 – 15	3 3/8 – 5 5/8	30	113
3	9318	RT-RRT	115-1-60	30	1/4	8 – 15	4 – 5 5/8	30	120
3	9319	RT-RRT	230-3-60	30	1/4	8 – 15	4 – 5 5/8	30	120
3	9320	RT-RRT	460-3-60	30	1/4	8 – 15	4 – 5 5/8	30	120

Can be modified to fit larger beams

Flat tread wheel available

Beam size and voltage required for ordering

Apply for other than standard travel speeds

## Industrial style chain container

Convenient chain containers are available for installation on every model. Container stores slack chain and removes it from work area. (Flat black powder coat finish)

**Specifications**

Product code	Lodestar hoist model	Maximum length of lift (ft.)	Length of chain bucket (in.)
2450	A-AA-B-C-F	10	8
2451	E-H	10	11
2451	A-AA-B-C-F	20	11
2451	J-JJ-L-LL	10	11
2453	R-RR	10	17
2453	J-JJ-L-LL	20	17
2452	E-H-J-JJ-L-LL	15	14
2453	E-H	20	17
2455	R-RR	15	23
2456	R-RR	20	31
2455	RT-RRT	10	23
2457	RT-RRT	15	36
2457	RT-RRT	20	36
2458	A-AA-B-C-F	140	48
2458	E-H	70	48
2458	J-JJ-L-LL	90	48
2458	R-RR	45	48
2458	RT-RRT	30	48



**\* ⚠ WARNING**

**Overloading and improper use can result in injury.**

**To avoid injury:**

- Do not exceed working load limit, load rating or capacity.
- Do not use to lift people or loads over people.
- Use only alloy chain for overhead lifting.
- Read and follow all instructions.